

# BASKET STRAINERS

## Steel / Stn. Stl. - 300B Series

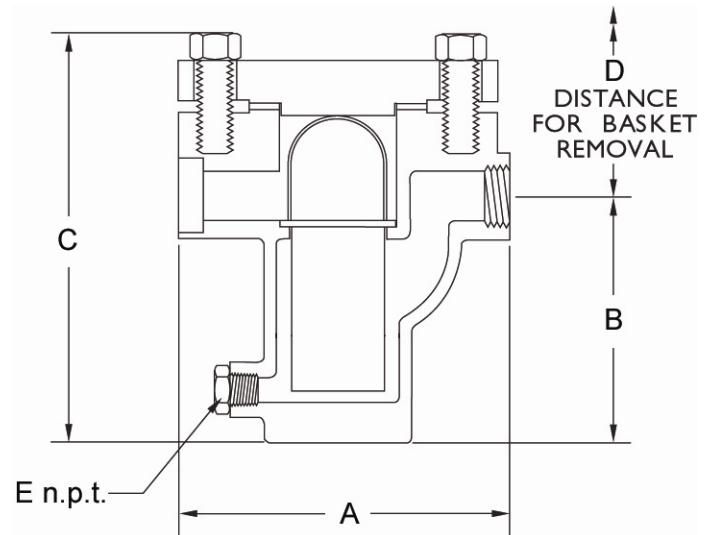

Model 300BTSB (Threaded) – Carbon Steel  
 Model 300BSWSB (Socket Weld) – Carbon Steel  
 Model 300BTSSB (Threaded) – Stainless Steel  
 Model B300BSWSSB (Socket Weld) – Stainless Steel



### RATINGS

PMO (maximum operating pressure): 720 psi @ 100°F  
 150 psi @ 900°F

### FEATURES

- **SCREENS:** 1/32" perforated type 304 stainless steel on sizes up to 1-1/2". 3/64" perforated type 304 stainless steel on 2"  
 Optional screen material and sizes are available upon request
- **COVER:** Flanged and gasketed covers are supplied on all sizes as standard.

### MATERIALS

PART	300BTSB (Carbon Stl.)	300BTSSB (Stn. Stl.)
Body	A126-WCB	A351-CF8M
Cover	A126-WCB	A351-CF8M
Screen	304 Stainless Steel	304 Stainless Steel
Plug	A105	A182-316
Gasket	304SS Spiral Wound	304SS Spiral Wound
Bolts	A193-B7	A193-B8-1

### DIMENSIONS AND WEIGHTS

Size		DIMENSIONS										Weight	
		A		B		C		D		E			
mm	in	mm	in	mm	in	mm	in	mm	in	mm	in	kg	lbs
15	1/2	156	6-1/8	102	4	179	7-1/16	146	5-3/4	10	3/8	8.2	18
20	3/4	171	6-3/4	127	5	213	8-3/8	189	7-1/2	10	3/8	10.9	24
25	1	171	6-3/4	127	5	213	8-3/8	189	7-1/2	15	1/2	10.9	24
32	1-1/4	206	8-1/8	197	7-3/4	302	11-7/8	281	11	20	3/4	19.5	43
40	1-1/2	206	8-1/8	197	7-3/4	302	11-7/8	281	11	20	3/4	19.5	43
50	2	229	9	197	7-3/4	314	12-3/8	297	11-3/4	25	1	26.3	58

Colton has a policy of continuous product research and improvement and reserves the right to change design and specifications without notice

