

RESILIENT SEATED BUTTERFLY VALVES

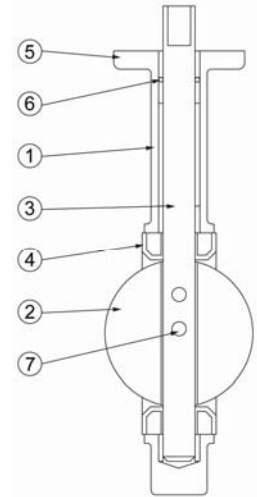

FEATURES

Body:

- High strength ductile iron lugs
- Full rating as standard with one flange removed (lug style only)
- Full rating dead end service (lug style only)

Seat:

- Phenolic backed elastomers
- Full vacuum service capabilities
- Primary & secondary shaft seals (upper & lower)
- Seats cannot be lipped in on installation
- Non-collapsible
- Flange gaskets are not required
- Superior shaft support at elastomer/disc interface
- Discs are machined to suit the seat flat to provide maximum sealing surfaces with reduced torque & wear
- Eliminates media exposure to shaft journal

Disc:

- Machined & polished disc edge
- Precision disc flats
- Wide seating surface ensure positive bubble tight seal
- Uniform contact around entire circumference minimizing wear, reducing torque & increasing cycle life

Bushings:

- 3 bushings, non-metallic, low co-efficient of friction, totally isolate the shaft from the body journal
- Positive shaft alignment
- Prevents shaft seizure in the body journals
- Eliminates side loading on actuators
- Reduced bushing torques

Shaft:

- Through shaft design
- Shaft diameters to AWWA CL-75B in sizes 3" to 12"
- Blow out proof shaft, reduces disc deflection

Interchangeability:

- Interchangeability with all butterfly valves in conformance to industry standards

MATERIALS

Item	Part	Description
1	Body	Cast Iron – ASTM A126-B
2	Disc	Ductile Iron Electrolytic Nickel Plated Aluminum Bronze 316 Stainless Steel
3	Shaft	416 Stainless Steel (316 Stainless Steel on models with 316SS disc)
4	Seat	Buna-N EPDM
5	Bushings x 4	Teflon Impregnated Fiberglass Backed
6	Seal	Buna-N O-Ring
7	Pin	316 Stainless Steel ^{2 3}
	Key	Carbon Steel (sizes 12" to 48")
	Screws	18-8 Stainless Steel ¹

NOTES:

1. Dead end service screws are standard on lug body valves only.
2. Valve sizes 6" and larger are equipped with two (2) pins.
3. Valve sizes 4" and smaller are equipped with one (1) pin.

STANDARDS OF CONSTRUCTION

Component	Standard
General Design	API 609
Mounting Pad	ISO 5211
Laying Length	API 609, MSS SP-67, ISO 5752
Inspection and Testing	API 598

RATINGS

PMO (maximum operating pressure) up to 12":	200 psi @ 150°F 180 psi @ 225°F
PMO (maximum operating pressure) 14" to 24":	150 psi @ 150°F 140 psi @ 225°F
PMO (maximum operating pressure) 30" to 48":	150 psi @ 150°F 100 psi @ 225°F
TMO (maximum operating temperature) Buna-N Seat:	-10°F to 180°F
EPDM Seat:	-10°F to 225°F



RESILIENT SEATED BUTTERFLY VALVES

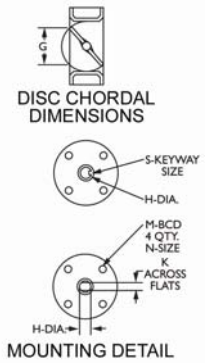
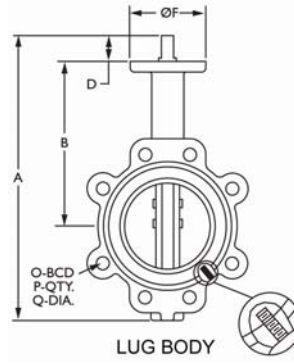
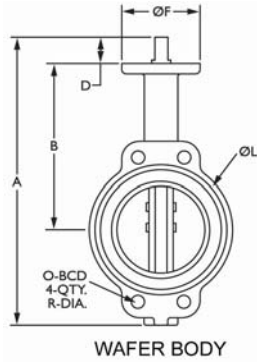
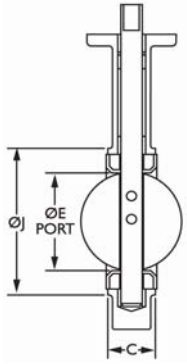

VALVE DIMENSIONS AND Cv VALUES (GPM @ 1 psid)

Size		A		B		C		D		E		F		G		H	
mm	in	mm	in	mm	in	mm	in	mm	in	mm	in	mm	in	mm	in	mm	in
50	2	273	10.75	161	6.34	42	1.66	32	1.25	53	2.09	76	3.00	32	1.25	13	0.50
65	2-1/2	296	11.65	175	6.89	44	1.75	32	1.25	65	2.54	76	3.00	47	1.84	13	0.50
75	3	308	12.12	181	7.13	45	1.78	32	1.25	80	3.13	76	3.00	64	2.50	13	0.50
100	4	346	13.62	200	7.87	52	2.06	32	1.25	105	4.13	92	3.63	89	3.50	16	0.63
125	5	372	14.65	213	8.39	54	2.14	32	1.25	123	4.86	92	3.63	111	4.38	19	0.75
150	6	397	15.63	226	8.90	56	2.19	32	1.25	156	6.13	92	3.63	146	5.75	19	0.75
200	8	480	18.90	260	10.25	61	2.39	44	1.75	203	8.00	114	4.50	194	7.63	22	0.88
250	10	540	21.25	292	11.50	66	2.58	44	1.75	251	9.87	114	4.50	242	9.50	29	1.13
300	12	624	24.57	337	13.27	77	3.03	44	1.75	301	11.87	140	5.50	292	11.50	32	1.25
355	14	679	26.75	368	14.50	76	3.00	44	1.75	334	13.13	140	5.50	325	12.81	32	1.25
405	16	760	29.94	400	15.75	87	3.41	51	2.00	391	15.38	197	7.75	381	15.00	33	1.30
455	18	802	31.56	422	16.61	106	4.16	51	2.00	441	17.38	197	7.75	428	16.87	38	1.50
510	20	906	35.65	480	18.90	132	5.19	64	2.53	492	19.38	197	7.75	475	18.69	41	1.63
610	24	1091	42.97	562	22.13	152	6.00	70	2.75	592	23.31	276	10.88	574	22.58	51	2.00

Size		J		K		L		M		N		O		P	Q
mm	in	mm	in	mm	in	mm	in	mm	in	mm	in	mm	in		
50	2	100	3.94	9	0.349	102	4.00	50	1.97	7	0.276	121	4.75	4	5/8"-11 UNC
65	2-1/2	121	4.75	9	0.349	121	4.75	50	1.97	7	0.276	140	5.50	4	5/8"-11 UNC
75	3	127	5.00	9	0.349	130	5.13	50	1.97	7	0.276	152	6.00	4	5/8"-11 UNC
100	4	156	6.13	11	0.437	171	6.75	70	2.76	10	0.394	191	7.50	8	5/8"-11 UNC
125	5	191	7.50	13	0.500	197	7.75	70	2.76	10	0.394	216	8.50	8	3/4"-10 UNC
150	6	213	8.38	13	0.500	219	8.63	70	2.76	10	0.394	241	9.50	8	3/4"-10 UNC
200	8	268	10.57	16	0.625	268	10.56	102	4.01	12	0.472	298	11.75	8	3/4"-10 UNC
250	10	325	12.81	21	0.812	256	10.06	102	4.01	12	0.472	362	14.25	12	7/8"-9 UNC
300	12	403	15.88	—	—	406	16.00	102	4.01	12	0.472	432	17.00	12	7/8"-9 UNC
355	14	437	17.19	—	—	435	17.13	102	4.01	12	0.472	476	18.75	12	1"-8 UNC
405	16	488	19.21	—	—	508	20.00	140	5.51	18	0.709	540	21.25	16	1"-8 UNC
455	18	539	21.22	—	—	543	21.38	140	5.51	18	0.709	578	22.75	16	1-1/8"-7 UNC
510	20	594	23.38	—	—	592	23.38	140	5.51	18	0.709	635	25.00	20	1-1/8"-7 UNC
610	24	816	32.13	—	—	708	32.13	165	6.49	23	0.906	749	29.50	20	1-1/4"-7 UNC

Size		R		S		Valve Cv Values					
						Disc Position in degrees					
						20°	40°	50°	60°	70°	90°
mm	in	mm	in								
50	2	17	0.687	—	5	24	45	64	90	135	
65	2-1/2	17	0.687	—	8	37	65	89	144	220	
75	3	17	0.687	—	12	39	70	116	183	302	
100	4	17	0.687	—	17	78	139	230	364	600	
125	5	21	0.812	—	29	133	237	392	620	1022	
150	6	21	0.812	—	45	205	366	605	958	1579	
200	8	21	0.812	—	89	408	727	1202	1903	3136	
250	10	24	0.937	—	151	694	1237	2047	3240	5340	
300	12	24	0.937	—	234	1072	1911	3162	5005	8250	
355	14	27	1.062	0.25 x 1.00	338	1549	2761	4568	7230	11917	
405	16	27	1.062	0.31 x 1.57	464	2130	3797	6282	9942	16388	
455	18	32	1.250	0.37 x 1.81	615	2822	5028	8320	13168	21705	
510	20	32	1.250	0.37 x 1.81	791	3628	6465	10698	16931	27908	
610	24	32	1.250	0.5 x 2.36	1222	5605	9989	16528	26157	43116	

NOTES:

- Quantity P and dimension Q refer to lug style. Dimension R refers to wafer style.
- Dimension C is the installed dimension. Approximately 1/8" wider when relaxed.
- Valves designed for installation between ASME B16.1 Class 125 and ASME B16.5 Class 150 flanges.
- Gaskets are not required and should not be used.



RESILIENT SEATED BUTTERFLY VALVES

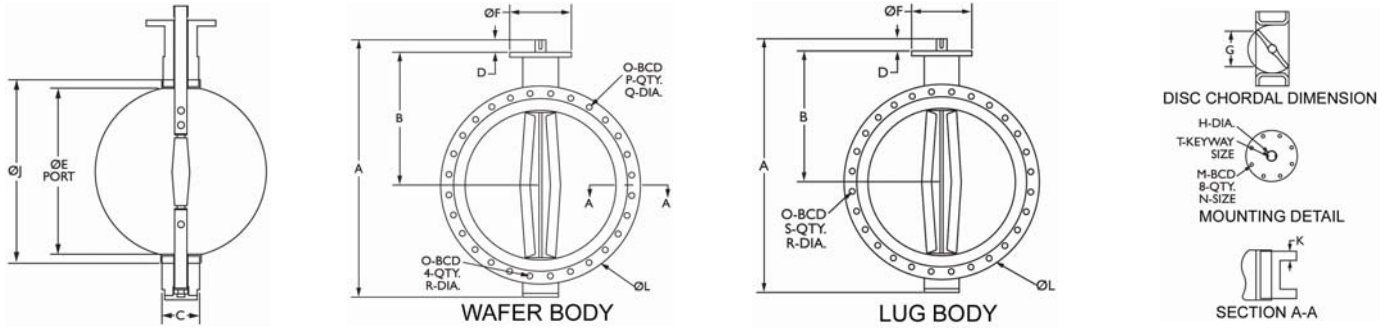

VALVE DIMENSIONS AND Cv VALUES (GPM @ 1 psid)

Size		A		B		C		D		E		F		G		H	
mm	in	mm	in	mm	in	mm	in	mm	in	mm	in	mm	in	mm	in	mm	in
750	30	1284	50.56	660	26.00	167	6.56	67	2.63	725	28.56	300	11.81	705	27.75	63	2.50
900	36	1487	58.53	721	28.38	203	8.00	118	4.63	842	33.13	300	11.81	813	32.00	75	2.94
1050	42	1785	70.25	857	33.75	251	9.88	150	5.91	998	39.31	300	11.81	965	38.00	95	3.75
1200	48	1954	76.91	940	37.00	276	10.88	150	5.91	1127	44.38	348	13.75	1090	42.91	105	4.13

Size		J		K		L		M		N		O		P		Q	
mm	in	mm	in	mm	in	mm	in	mm	in	mm	in	mm	in	mm	in	mm	in
750	30	795	31.28	54	2.13	984	38.75	254	10.00	18	0.708	914	36.00	24		35	1.38
900	36	974	37.28	60	2.38	1168	46.00	254	10.00	18	0.708	1086	42.75	28		41	1.63
1050	42	1124	44.25	67	2.63	1346	53.00	254	10.00	18	0.708	1257	49.50	32		41	1.63
1200	48	1264	49.75	70	2.75	1511	59.50	298	11.75	22	0.866	1422	56.00	40		41	1.63

Size		R	S	T	Valve Cv Values Disc Position in degrees					
mm	in				20°	40°	50°	60°	70°	90°
750	30	1-1/4"-7 UNC-2B	25	0.71 x 2.48	2036	7461	11777	17578	26634	58121
900	36	1-1/2"-6 UNC-2B	32	0.79 x 3.94	3021	11055	17449	26086	39731	86375
1050	42	1-1/2"-6 UNC-2B	36	0.98 x 5.51	4738	17361	27405	40903	61974	135240
1200	48	1-1/2"-6 UNC-2B	44	1.10 x 5.51	6188	22675	35794	53424	80945	176640

- NOTES:**
- Quantity S and dimension R refer to lug style. Quantity P and dimension Q refer to wafer style.
 - Dimension C is the installed dimension. Approximately 3/8" wider when relaxed.
 - Valves designed for installation between ASME B16.1 class 125 and ASME B16.47 series A class 150 flanges.
 - Gaskets are not required and should not be used.



MANUAL ACTUATOR DIMENSIONS

Lever

Valve Size		A		B		WEIGHT	
mm	in	mm	in	mm	in	kg	lbs
50 - 150	2 - 6	252	10	24	1	1.4	3.0
100 - 300	8 - 12	359	14.1	36	1.4	1.8	4.0

Gear

Valve Size		A		B		C		D		E		F		G		H		Weight	
mm	in	mm	in	mm	in	mm	in	mm	in	mm	in	mm	in	mm	in	mm	in	kg	lbs
50-150	2-6	127	5.0	45	1.7	28	1.1	105	4.1	41	1.6	66	2.6	152	6.0	193	7.6	4.5	10
200-250	8-10	178	7.0	66	2.6	34	1.3	152	6.0	46	1.8	84	3.3	305	12.0	318	12.5	12.7	28
300-350	12-14	198	7.8	76	3.0	38	1.5	170	6.6	51	2.0	89	3.5	305	12.0	318	12.5	15.0	33
400	16	292	11.5	112	4.4	41	1.6	262	10.3	64	2.5	117	4.6	305	12.0	411	16.2	32.2	71
450-600	18-24	313	12.3	120	4.7	73	2.8	274	10.8	75	2.9	162	6.3	305	12.0	342	13.4	53.5	118



RESILIENT SEATED BUTTERFLY VALVES



VALVE SEATING TORQUE (in./lbs.)

Valve Size		150 psi		200 psi	
mm	in	Lubricated	Non-Lubricated	Lubricated	Non-Lubricated
50	2	—	—	132	211
65	2-1/2	—	—	191	306
75	3	—	—	292	467
100	4	—	—	433	693
125	5	—	—	697	1115
150	6	—	—	907	1542
200	8	—	—	1697	2885
250	10	—	—	2857	4857
300	12	—	—	4338	6941
355	14	6088	9132	—	—
400	16	8356	12534	—	—
450	18	11198	16797	—	—
500	20	14938	22407	—	—
600	24	23350	35025	—	—

WEIGHTS – Valve Body Only

Valve Size		Lug Body		Wafer Body	
mm	in	kg	lbs	kg	lbs
50	2	3.2	7	2.7	6
65	2-1/2	3.6	8	3.2	7
75	3	6.3	14	4.5	10
100	4	11.8	26	5.9	13
125	5	12.7	28	8.2	18
150	6	14.1	31	9.1	20
200	8	22.2	49	14.5	32
250	10	32.7	72	19.0	42
300	12	47.6	105	31.7	70
355	14	70.3	155	43.1	95
400	16	88.4	195	53.1	117
450	18	104.0	230	74.8	165
500	20	180.0	396	125	275
600	24	277.0	610	200	440

- NOTES:**
1. Selection of actuator torque output must meet or exceed the maximum torque required by the valve.
 2. Under certain conditions, hydrodynamic torque can exceed seating and unseating torques and must be considered in the selection of actuators.
 3. Valve seating torque values are available with 50, 75 and 100 psi when valves with undercut discs are supplied. Please consult factory for details.

ORDERING CODES

	BODY MATERIAL	BODY TYPE	VALVE TYPE	-	DISC MATERIAL	SEAT MATERIAL	VALVE OPERATOR
Example:	CI	W	B	-	D	B	L
	CI – Cast Iron	W – Wafer L – Lug	B – Butterfly		D – Ductile Iron B – Aluminum Bronze S – Stainless Steel	B – Buna-N E – EPDM	L – 10 Position Lever G – Handwheel Gear P – Pneumatic Actuator E – Electric Actuator B – No Operator, Bare Shaft

Colton has a policy of continuous product research and improvement and reserves the right to change design and specifications without notice

